

SEQUENCE® Primer Alpha

■ Primer Alpha Model 6800PRM19

The all in one! The Primer Alpha series integrates a basket-type pre-filter and self-priming capabilities into one efficient package for trouble free operation. Since an internal diffuser allows for displacement of trapped air, this type of pump will continue to move water even when there is some air in the line. The integrated strainer basket on all the primer units helps protect the internal rotating parts of the pump from damage due to external debris being pulled into the pump, i.e. branches, leaves, etc. The simple cover allows for quick cleaning and replacement. Because the unit can operate for short periods of time without full water flow, it provides a small cushion of comfort to the owners of those systems where the water level drops below the intake point. Motor is totally-enclosed, fan-cooled for durability. 3 year limited warranty. Made in the USA. 115V or 230V. **8-foot 115V cordset included.**

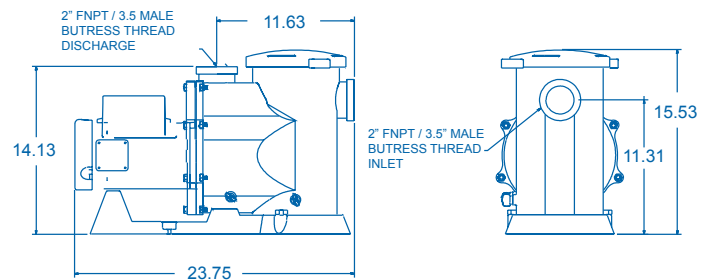
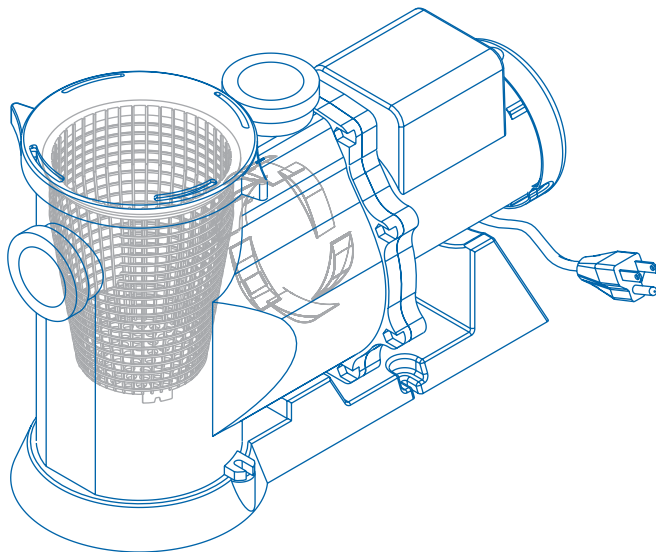

(Low-Speed)

Model 6800PRM19	
List price	\$851.00
Inlet	2" FNPT / 3.5 Male Butress
Discharge	2" FNPT / 3.5 Male Butress
Max flow, GPH	6800
Max head, Ft	19'
Max Power, Watts	369
Max Current, Amps	3.93
115 / 230 @ Volts	115
Motor HP	1/2, 1/3
MotorType	56YZ
Motor Enclosure	TEFC
Shipping Weight	55.00 LBS
Box Dimensions	28" x 14" x 18"

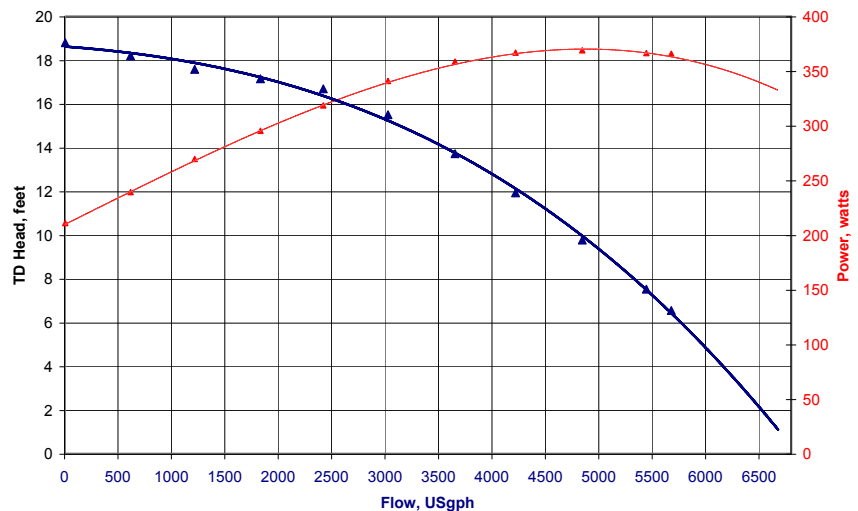

Proudly Made in the USA

Sustainable, Efficient.

©2008 SEQUENCE PUMPS A DIVISION OF MDM INC.